

# JEYCO 3 POINT SWING MOORING SYSTEMS

VESSEL OWNER TO ENSURE SUITABLE HAWSER CONNECTION IS USED. CHAFE CHAINS OF SUITABLE LENGTH/STRENGTH SHOULD BE USED TO ENSURE THAT THE HAWSER CANNOT CHAFE ON ANY PART OF THE VESSEL'S STRUCTURE.

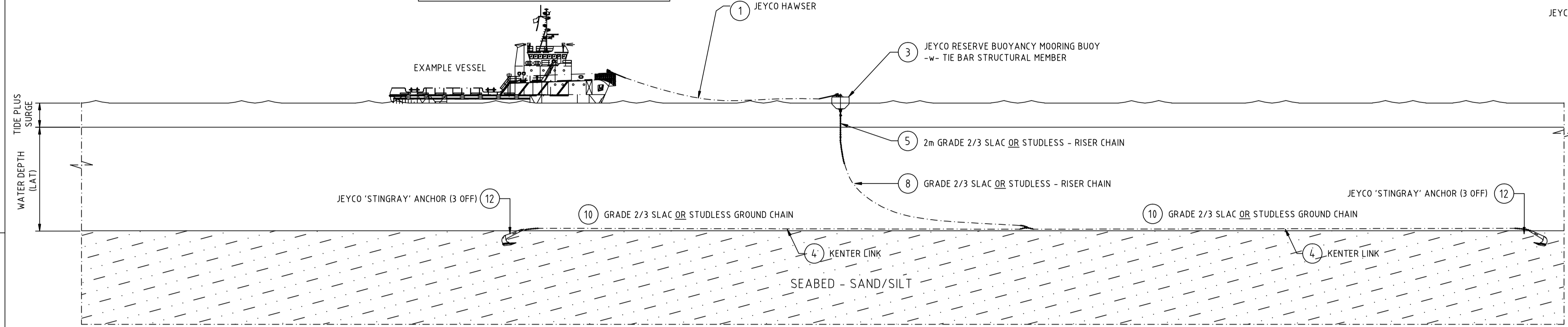

MOORING SYSTEM PROFILE

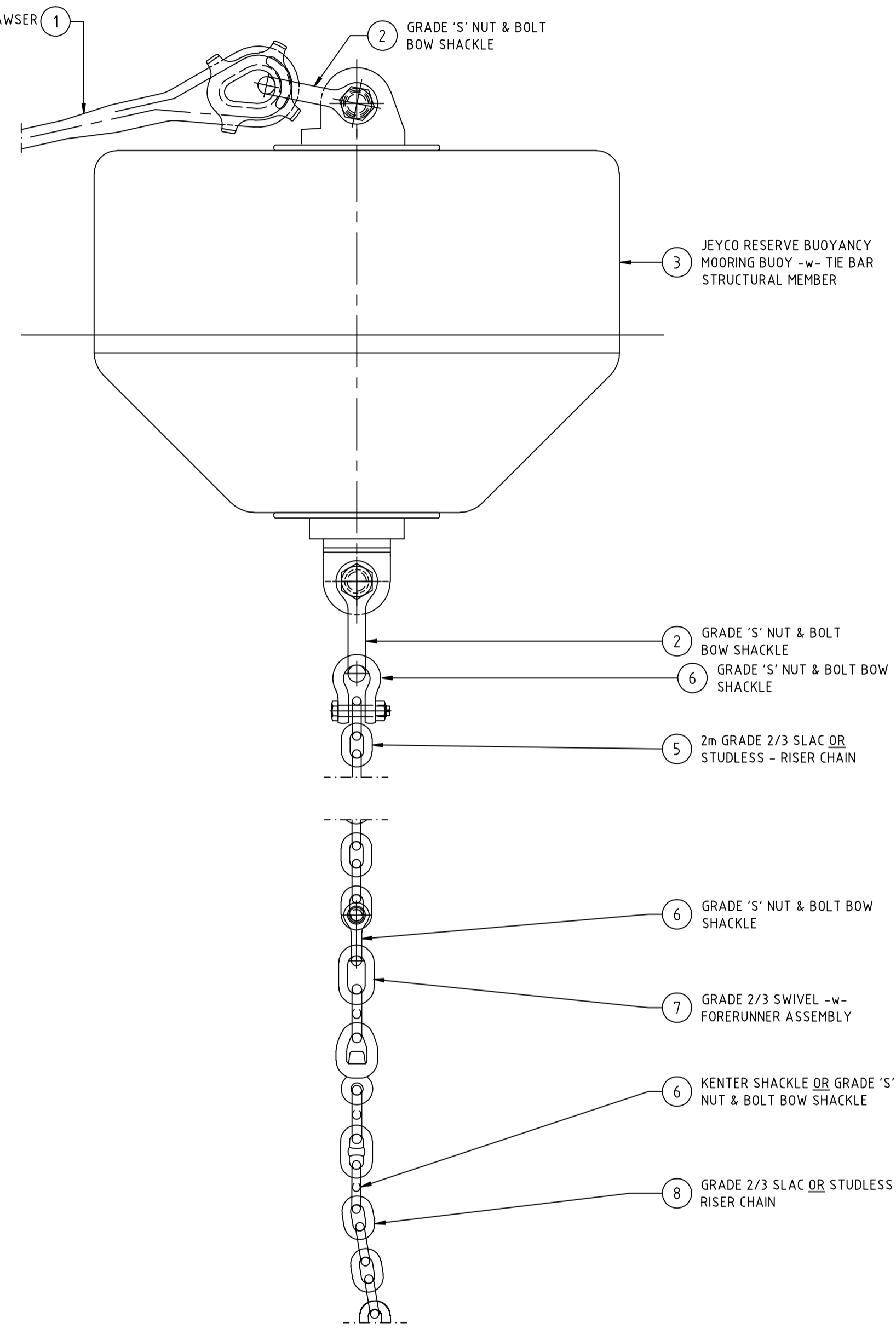

BUOY CONNECTION DETAILS

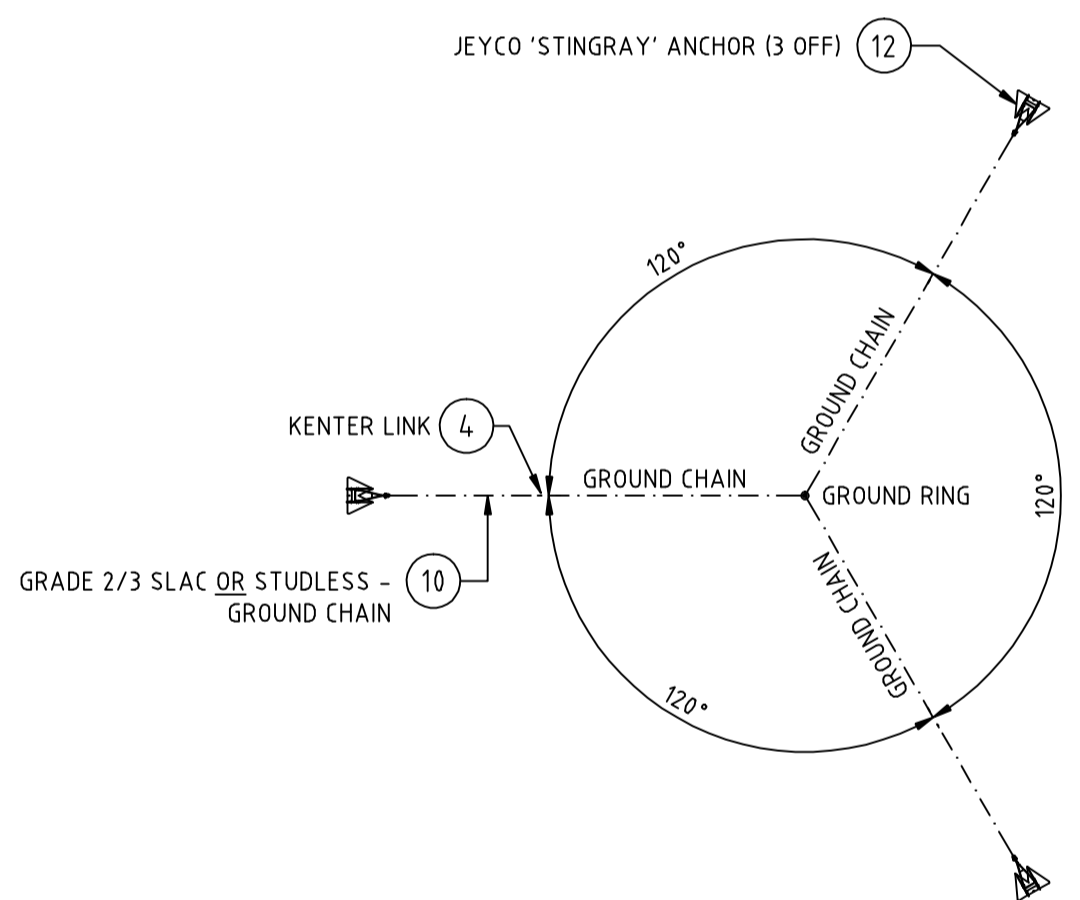

MOORING ARRANGEMENT DETAILS

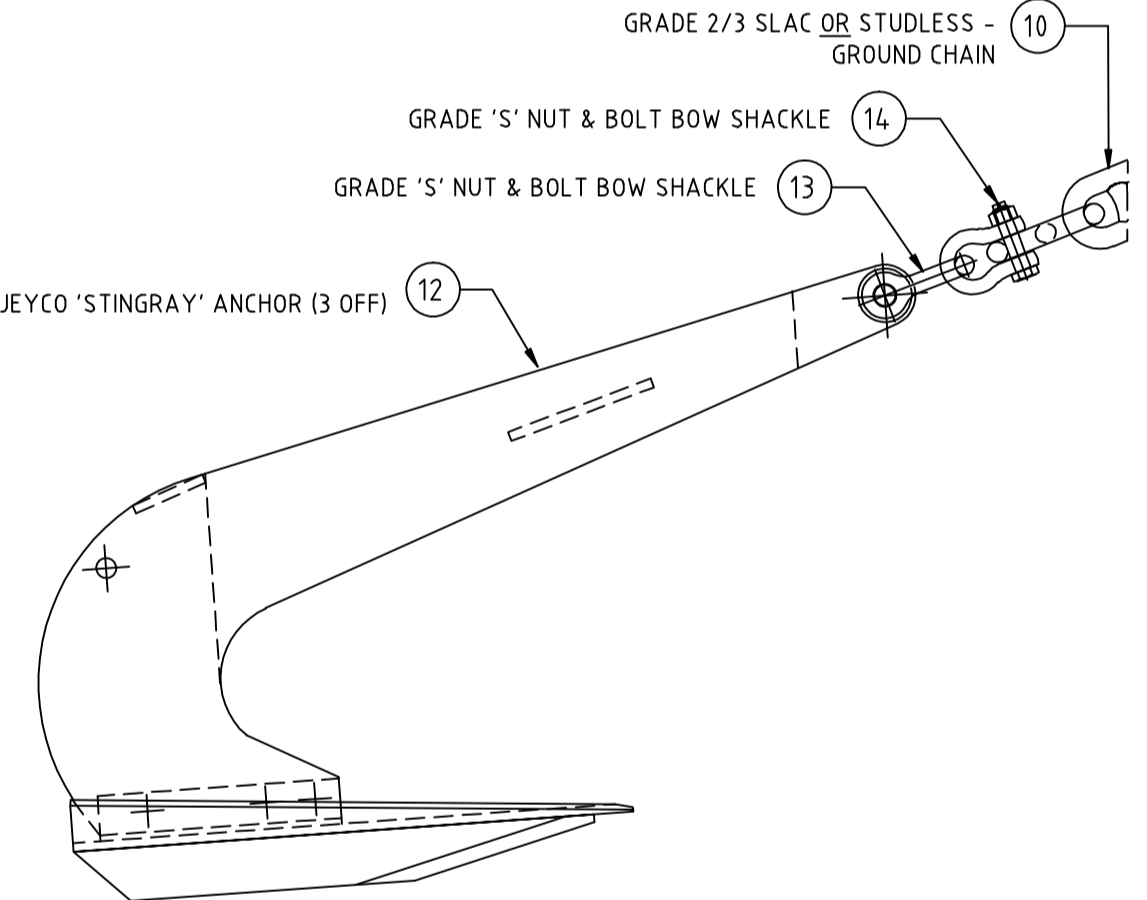

ANCHOR CONNECTION DETAIL

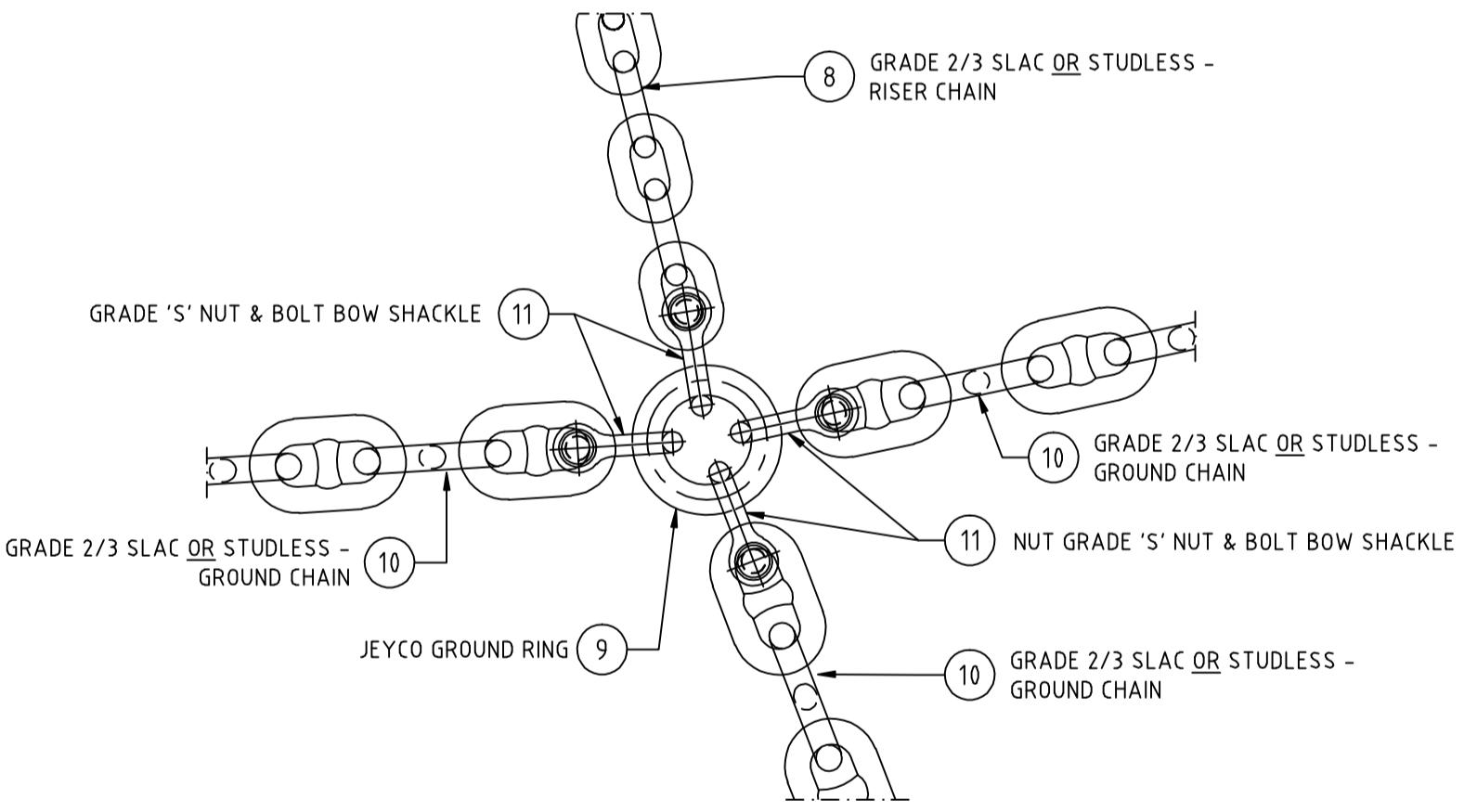

GROUND CONNECTION DETAILS

**NOTES:**

1. MOORING SYSTEM TO BE DESIGNED FOR INDIVIDUAL VESSEL.
2. THE DESIGN OF THE MOORING SYSTEM ASSUMES THAT THE ANCHORS ARE PROPERLY SET IN BELOW THE SEABED.
3. WHERE THE HAWSER/CHAFE CHAINS ARE CONNECTED TO VESSEL, BOLLARDS & DECK TO HAVE SUFFICIENT STRENGTH TO MAINTAIN LOADS.
4. ALL SHACKLES SHALL BE TO US FEDERAL SPECIFICATION RR-C-271. ALL SHACKLES SHALL BE FITTED WITH SAFETY PINS.
5. MOORINGS DESIGNED IN ACCORDANCE WITH METHODS OUTLINED IN BRITISH STANDARD BS 6349:6:1989.
6. CHAIN SHALL BE NEW OR OF KNOWN HISTORY WITH CURRENT BREAKING LOAD CERTIFICATES.

**MOORING PARTS LIST:**

ITEM	DESCRIPTION
1.	NYLON DOUBLE BRAID ROPE HAWSER
2.	GRADE 'S' NUT & BOLT BOW SHACKLE
3.	RESERVE BUOYANCY MOORING BUOY WITH TIE BAR
4.	KENTER LINK
5.	2m x RISER CHAIN
6.	GRADE 'S' NUT & BOLT BOW SHACKLE
7.	SWIVEL -w- FORERUNNER ASSEMBLY
8.	RISER CHAIN
9.	JEYCO GROUND RING
10.	GROUND CHAIN
11.	GRADE 'S' NUT & BOLT BOW SHACKLE
12.	'JEYCO' HIGH HOLDING POWER ANCHOR
13.	GRADE 'S' NUT & BOLT BOW SHACKLE
14.	GRADE 'S' NUT & BOLT BOW SHACKLE

EXAMPLE ONLY  
CONCEPT PURPOSES ONLY

This drawing and all information shown hereon are the exclusive property of JEYCO (1992) PTY. LTD. The recipient agrees not to reproduce the drawing, to return it upon request, and that no disclosure of the drawings or the information shown hereon will be made to a third party without the prior written consent from JEYCO (1992) PTY. LTD.

ISSUE	DATE	BY	REVISION	CLIENT APPROVAL
1	21/06/10	TRH	ISSUED FOR COMMENT	
0	29/01/07	TRH	ISSUED FOR COMMENT	

DRAWING TITLE: STORM & CYCLONE MOORING ARRANGEMENT

SHEET TITLE: MOORING ARRANGEMENT & DETAILS

CLIENT: JEYCO

**JEYCO**  
MOORING AND RIGGING EQUIPMENT

65 DISCOVERY DRIVE, BIBRA LAKE,  
WESTERN AUSTRALIA 6163  
TEL: (08) 9418 7500 FAX: (08) 9418 7511  
www.jeyco.com.au

DRAWN	CHECKED	APPROVED	SCALE	DRAWING NO.	REV
TRH	TRH	TRH	NTS A3	Z007-MOR-DWG-001	1